SPS-2110PFWG (RoHS Compliant)
64GFC / 10 km / 1310 nm Digital Diagnostic SFP56 LC SINGLE-MODE TRANSCEIVER

FEATURES

- Up to 57.8 Gbps Bi-directional Data Links
- Duplex LC Connector
- Compliant with Fibre Channel 64GFC-LW (PAM4)
- Support Fibre Channel 32GFC and 16GFC data rates (NRZ)
- Distance up to 10 km SMF
- Cooled 1310nm EML Transmitter
- Rx Output Amplitude Control Implemented
- SFF-8472 Digital Diagnostic Function
- AC/AC Coupling according to MSA
- Single +3.3 V Power Supply
- RoHS Compliant
- 0 to 70°C Operation
- Class 1 Laser International Safety Standard IEC-60825 Compliant

APPLICATIONS

- Fibre Channel 64GFC-LW
- Fibre Channel 32GFC and 16GFC

DESCRIPTION

The SPS-2110PFWG series single mode transceiver is a small form factor pluggable module for bi-directional serial optical data communications such as Fibre Channel 64GFC-LW. It is with the SFP+ 20-pin connector to allow hot plug capability. Digital diagnostic functions are available via an I²C. This module is designed for single mode fiber and operates at a nominal wavelength of 1310 nm. The transmitter section consists of a cooled 1310nm EML and is a class 1 laser compliant according to International Safety Standard IEC-60825. The receiver section uses an integrated InGaAs detector preamplifier (IDP) mounted in an optical header and a rate selection clock data recovery (CDR) IC.

LASER SAFETY

This single mode transceiver is a Class 1 laser product. It complies with IEC-60825 and FDA 21 CFR 1040.10 and 1040.11. The transceiver must be operated within the specified temperature and voltage limits. The optical ports of the module shall be terminated with an optical connector or with a dust plug.

ORDER INFORMATION

P/No.	Bit Rate (Gb/s)	FC	Modulation Format	Distance (km)	Wavelength (nm)	Package	Case Temp (°C)	RoHS Compliant
SPS-2110PFWG	Up to 57.8	64G/32G/16G	PAM4/NRZ	10	1310	SFP56 with DMI	0 to 70	Yes

Absolute Maximum Ratings					
Parameter	Symbol	Min	Max	Units	Notes
Storage Temperature	Tstg	-40	85	°C	
Relative Humidity	RH	5	85	%	Non-condensing
Operating Case Temperature	Topr	0	70	°C	

Recommended Operating Conditions					
Parameter	Symbol	Min	Typ	Max	Units / Notes
Power Supply Voltage	Vcc	3.135	3.3	3.465	V
Power Dissipation	P _D			3.0	W
Operating Case Temperature	Topr	0		70	°C
Data Rate		14.025		28.9	GBd
		14.025		57.8	Gb/s

Transmitter Optical Specifications (Topr= 0 to 70°C, Vcc3 = 3.3V ±5%)						
Parameter	Symbol	Min	Typ	Max	Units	Notes
Output Center Wavelength	λ_c	1304.5		1317.5	nm	
Side Mode Suppression Ratio	SMSR	30			dB	
Average Launch Power	$P_{O, Avg}$	-4.5		4.2	dBm	1
Outer OMA	OMA_{outer}	-1.5		4	dBm	
Launch power in OMA_{outer} minus TDECQ		-2.9			dBm	
Transmitter and dispersion penalty eye closure for PAM4	TDECQ			4	dB	2
TDECQ- $10\log_{10}(C_{eq})$				4	dB	
Average Launch Power of OFF Transmitter				-16	dBm	
Extinction Ratio	ER	3.5			dB	
Optical return loss tolerance				15.6	dB	
Transmitter reflectance				-26	dB	3
Transmitter transition time				34	ps	20% - 80%
RIN_xOMA				-134	dB/Hz	

1. The value is calculated using an infinite extinction ratio at the lowest allowed transmit OMA_{outer} . A launched power below this value cannot be compliant; however, a value above this does not ensure interoperation with compliant receivers.
2. For FC-PI-7, TDECQ must be computed using a SER of 2.18×10^{-4} .
3. Transmitter reflectance is defined looking into the transmitter.

Receiver Optical Specifications (Topr= 0 to 70°C, Vcc3 = 3.3V ±5%)						
Parameter	Symbol	Min	Typ	Max	Units	Notes
Wavelength of Operation		1304.5		1317.5		
Damage Threshold		5.2			dBm	4
Average receive power		-10.8		4.2	dBm	
Receiver power (OMA)	OMA_{outer}			4	dBm	
Receiver reflectance				-26	dB	
Receiver sensitivity (OMA_{outer})@ 64GFC	Sen 1			-8.9	dBm	@ 28.9GBd, BER = 1.09E-4
Receiver sensitivity (OMA)@ 32GFC	Sen 2			-11.4	dBm	@ 28.05Gbps, BER = 1E-6
Receiver sensitivity (OMA)@ 16GFC	Sen 3			-10.2	dBm	@ 14.025Gbps, BER = 1E-12
LOS Assert	Pa	-30			dBm	5
LOS Deassert	Pd			-13	dBm	5
LOS Hysteresis		0.5		4	dB	

4. The receiver shall be able to tolerate, without damage, continuous exposure to an optical signal having this average power level. The receiver does not have to operate correctly at this input power.
5. Rx LOS pin output is controlled by software; Rx LOS assert/deassert delay time is < 100ms.

Electrical Characteristics						
Parameter	Symbol	Min	Typ	Max	Units	Notes
High-Speed Signal (CML) Interface Specification						
64GFC Singling Rate			28.9		GBd	+/- 100 ppm PAM4
32GFC Singling Rate			28.05		GBd	+/- 100 ppm NRZ
16GFC Singling Rate			14.025		GBd	+/- 100 ppm NRZ
Differential Input Impedance	R_{in}	90	100	110	Ω	
Differential Data Input Amplitude		900			mVpp	Internally AC coupled
Output Singling Rate		14.025		28.9	GBd	
Differential Output Impedance	R_{out}	90	100	110	Ω	
Differential Data Output Amplitude				900	mVpp	Internally AC coupled
Low-Speed Signal (LVTTTL) Interface Specification						
Input High Voltage		2.0		$V_{cc}+0.3$	V	

Input Low Voltage		GND		0.8	V	
Output High Voltage		2.4		V _{cc}	V	
Output Low Voltage		GND		0.5	V	

CONNECTION DIAGRAM

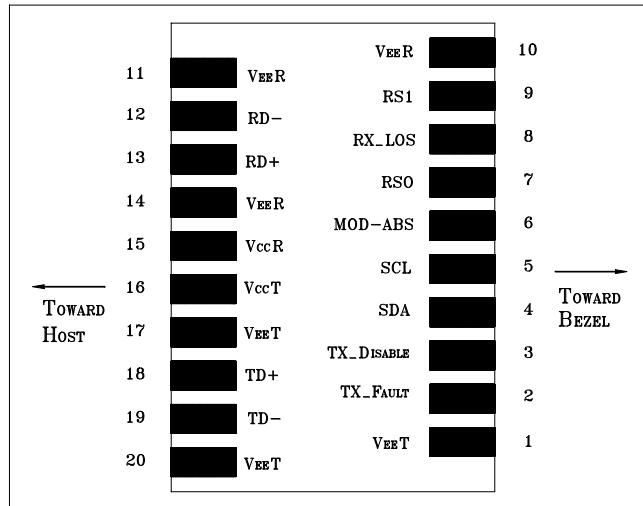

PIN	Signal Name	Description	PIN	Signal Name	Description
1	VEE T	Transmitter Signal Ground	11	VEE R	Receiver Signal Ground
2	TX_Fault	Transmitter Fault Indication. Logic “1” Output = Laser Fault. Logic “0” Output = Normal Operation	12	RD-	Inverse Receiver Data Out
3	TX_Disable	Logic “1” Input (or no connection) = Laser off, Logic “0” = Laser on.	13	RD+	Receiver Data Out
4	SDA	Modulation Definition 2 – Two wires serial ID Interface	14	VEE R	Receiver Signal Ground
5	SCL	Modulation Definition 1 – Two wires serial ID Interface	15	Vcc R	Receiver Power – 3.3V±5%
6	MOD-ABS	Modulation Definition 0 – Ground in Module	16	Vcc T	Transmitter Power – 3.3V±5%
7	RS0	RX Rate Select: See Rate Select Control This pin has an internal 30k pulldown to ground.	17	VEE T	Transmitter Signal Ground
8	RX_LOS	Loss of Signal Out (OC).	18	TD+	Transmitter Data In
9	RS1	TX Rate Select: See Rate Select Control This pin has an internal 30k pulldown to ground.	19	TD-	Inverse Transmitter Data In
10	VEE R	Receiver Signal Ground	20	VEE T	Transmitter Signal Ground

MODULE DEFINITION

Module Definition	PIN 4	PIN 5	PIN 6	Interpretation by Host
4	SDA	SCL	MOD-ABS	Serial module definition protocol

Module Definition 4 specifies a serial definition protocol. For this definition, upon power up, SDA and SCL appear as no connector (NC) and MOD-ABS is TTL LOW. When the host system detects this condition, it activates the serial protocol. The protocol uses the 2-wire serial CMOS E²PROM protocol of the ATMEL AT24C01A/02/04 family of components.

RATE SELECT CONTROL

1. TX & RX rates and modes can be controlled either by the hardware input pins or the register control bits.
2. TX & RX only operate at the same speed and mode.
3. TX & RX cannot be independently controlled.

TX & RX		Rate Select Control Inputs		
Rate	Mode	Software 64GFC Mode Software A2h Byte 119 Bit 2	RS0 Hardware Pin 7 or Software A2h Byte 110 Bit 3	RS1 Hardware Pin 9 or Software A2h Byte 118 Bit 3
16GFC	NRZ	0	0	0
32GFC	NRZ	0	0	1
32GFC	NRZ	0	1	0
32GFC	NRZ	0	1	1
64GFC	PAM4	1	X	X

RECOMMENDED CIRCUIT SCHEMATIC

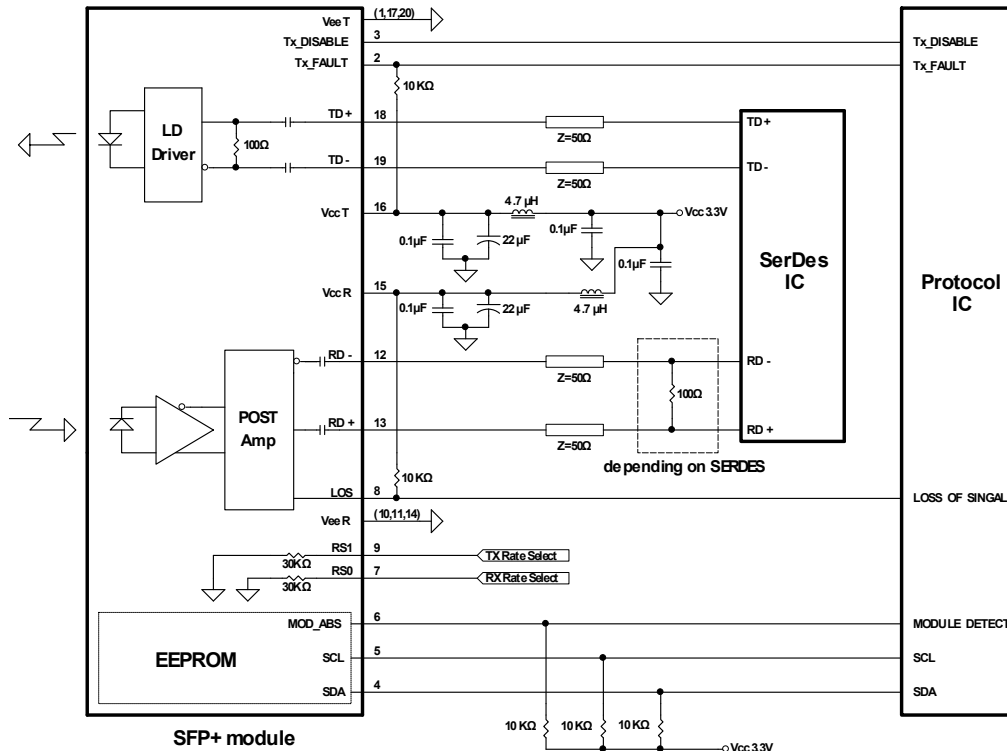

PACKAGE DIAGRAM

Units in mm

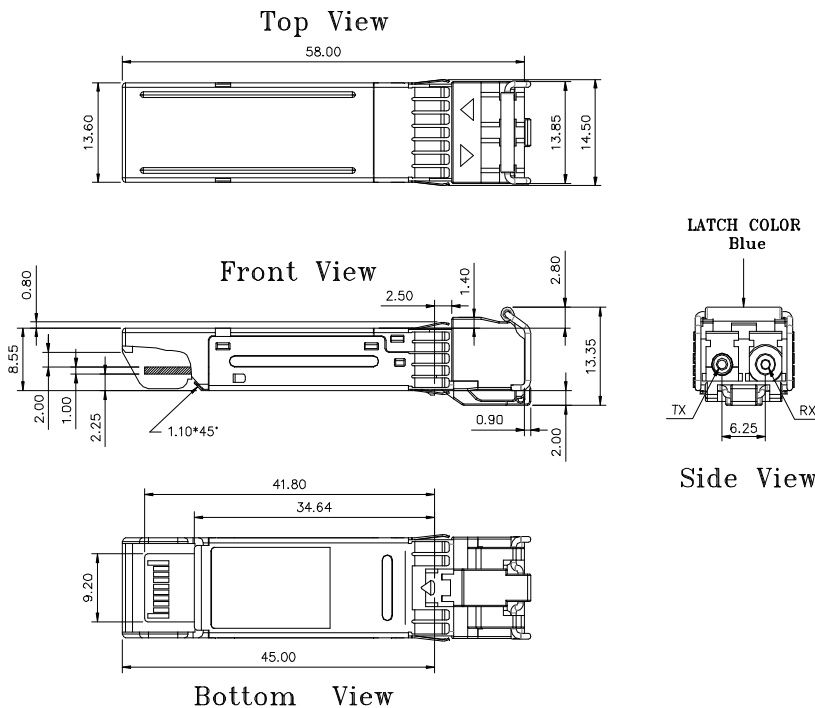

Note: Specifications subject to change without notice.

REVISION HISTORY

Version	Subject	Release Date
1.0	Initial datasheet	2023/2/13
1.1	Add Note 5: Rx_LOS pin output is controlled by software; Rx_LOS assert/deassert delay time is < 100ms.	2023/4/21
2.0	1. Add Feature: Rx Output Amplitude Control Implemented 2. Update Rate Select Control	2024/9/19